

(No Model.)

O. SCHLEMMER.  
WATER HEATING SYSTEM.

No. 598,327.

Patented Feb. 1, 1898.

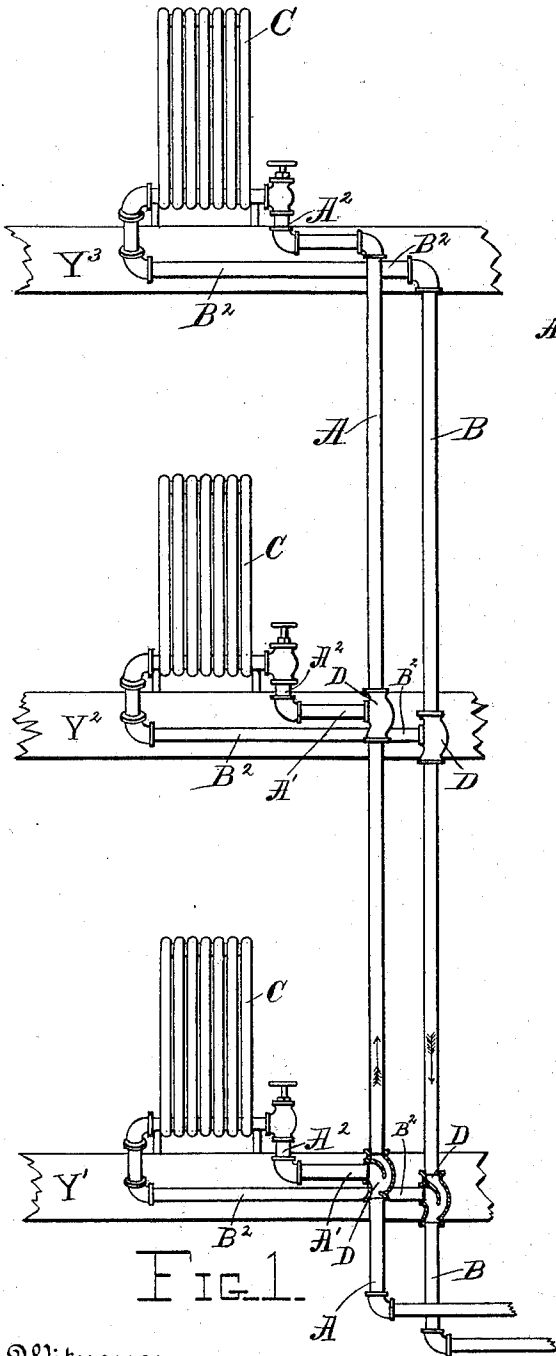

FIG. 1.

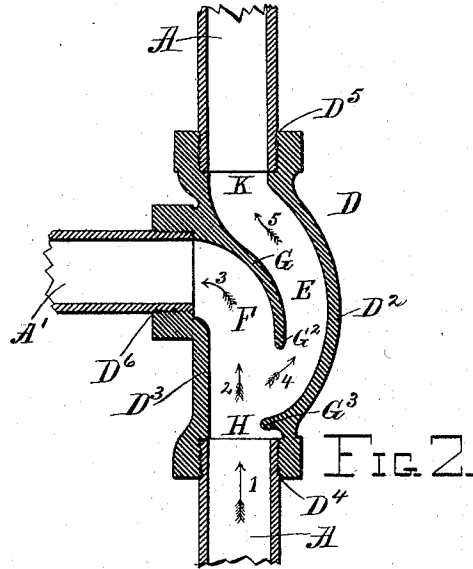

FIG. 2.

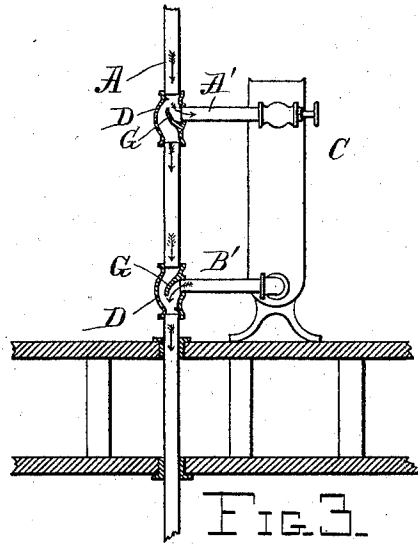

FIG. 3.

Witnesses

John H. Holt

Wm. H. Parker

Inventor  
O. Schlemmer  
by S. P. Fisher.  
Attorney

# UNITED STATES PATENT OFFICE.

OLIVER SCHLEMMER, OF CINCINNATI, OHIO.

## WATER-HEATING SYSTEM.

SPECIFICATION forming part of Letters Patent No. 598,327, dated February 1, 1898.

Application filed April 20, 1895. Serial No. 546,485. (No model.)

*To all whom it may concern:*

Be it known that I, OLIVER SCHLEMMER, a citizen of the United States, and a resident of the city of Cincinnati, in the county of Hamilton and State of Ohio, have invented certain new and useful Improvements in Water-Heating Systems, of which the following is a specification.

My invention relates to improvements in hot-water heating systems, and more particularly to a device whereby a more perfect and even distribution of hot water to the various radiators may be obtained. Besides insuring a more even distribution of heat my invention contemplates and is designed to secure many other results, some of which are to save the number of joints and extra piping, to diminish leakage, and reduce the weight of the whole system, obtaining a compact system free from all of the objections consequent upon the employment of extra piping and devices now employed to accomplish the same result.

In order to accomplish the objects of my invention, it consists of a novel device and arrangement, all of which will be more fully understood with reference to the accompanying drawings, in which similar parts are represented by similar letters throughout the several views.

Figure 1 represents a series of radiators with pipe connections provided with my improved device. Fig. 2 represents a vertical central sectional view of the device embodying my invention; and Fig. 3 represents a radiator provided with my improved device, showing how the same may be employed when the flow of water is from above.

The pipe-fitting as embodied in my invention is represented by D. Assuming that the feed-water comes from below, D<sup>4</sup> represents the entrance-opening to the fitting, into which the feed-pipe A is to be screwed. Directly above this entrance—that is, in the same axial line with the opening D<sup>4</sup>—is an opening D<sup>5</sup>, into which is screwed the upwardly-extending feed-pipe A. On the left of the fitting, as shown in Fig. 2, is another opening D<sup>6</sup>, into which is screwed the local feed-pipe A'.

H indicates the entrance-passage to the fitting D.

The openings D<sup>4</sup> and D<sup>6</sup> are connected by the passage F and the openings D<sup>4</sup> and D<sup>5</sup> by the passage E.

The mouth of the passage F lies beyond the entrance H and in a direct axial line therewith. The passage F from the point where it meets the entrance H is continued on and curved to one side of the fitting in a direction at right angles to the axial line of the fitting D and passes into the opening D<sup>6</sup>. The passage H at one side opens into the passage E. This passage E passes out to one side (to the right in Fig. 2) of the passage H and axial line of the fitting upward and again back into the axial line, when it connects with the opening D<sup>5</sup> at K. For the formation of this passage F the casing of the fitting is extended outward, as at D<sup>2</sup>.

I am enabled to obtain the arrangement of the water-passages as shown by the peculiar construction of the walls of the fitting in combination with an interior diaphragm G. This diaphragm crosses the interior of the fitting and the line of feed in the water-pipe in an oblique direction. The diaphragm is formed integral with the fitting, beginning above the opening D<sup>6</sup>, extending outwardly and downwardly across the axial line, and ending at G<sup>3</sup> on the right in Fig. 2 of the axial line of the fitting and below the lowest point of the opening D<sup>6</sup>.

Just above the opening D<sup>4</sup> and on the same side of the fitting as the passage E is a deflecting-flange G<sup>3</sup>. Thus the hot water passing through the pipe A in the direction of the arrow 1 will naturally have a tendency to continue its movement in a direct line coincident with the axis of the vertical feed-pipe. Then it will pass to the left of the diaphragm G, Figs. 1 and 2, and enter the passage F. The water will then be deflected by the curve of the diaphragm G and pass through the local feed-pipe A' into the radiator connected therewith.

The water is assisted in its deflection through the passage F by the flange G<sup>3</sup>. That portion of the hot water in feed-pipe A passing up on the right-hand side of the pipe A, Figs. 1 and 2, is deflected across the passage H toward the left, and therefore has a tendency to guide and throw the water passing with it toward the wall D<sup>3</sup>, and thus more

fully insure the delivery at the proper time of the entire bulk of hot water into the passage F.

After the hot water has passed through the passage F and through the pipe A' into the adjacent radiator C it will return through the return-pipe B to the heater. As soon as the radiator C has become filled with water and a current established therein the water will meet with more resistance in passing through the pipe A into the passage F. Therefore a portion of the feed-water will pass to the right, entering the passage E and thence through the opening D<sup>5</sup> into the feed-pipe, and will then continue on to the next radiator above if they are arranged as shown in Fig. 1, where Y<sup>1</sup>, Y<sup>2</sup>, and Y<sup>3</sup> represent a series of floors.

When the radiator connected to fitting D is filled, the currents of hot water will flow as indicated by the arrows in Fig. 2, the main volume will pass on in the direction of the arrow 1 and, if the radiator be filled, will divide, a portion taking the course of the arrows 2 and 3 and a portion the course of the arrows 4 and 5. When for any reason it becomes desirable to have the hot water delivered from above downward through the vertical pipes to the radiators, the system is reversed and the fitting will then be located substantially as shown in Fig. 3. In such even the former feed-pipe may become the return, as indicated. The hot water passing down through the feed-pipe A is deflected by means of the diaphragm G of the upper fitting, Fig. 3, into the radiator through the pipe A<sup>4</sup>. The hot water passes into the radiator, heating it, and coming out below through the pipe B' passes into the lower fitting D, whose diaphragm deflects the water downward, substantially as shown. At the same time all of the hot water in the upper portion of the feed-pipe which does not enter the radiator C passes down the feed-pipe A and passages E and downward, mingling (below the section of the pipe-fitting D) with the water coming from the radiator, and passes down to the next radiator, if any, to be heated. By the means shown and described I am thus enabled to combine the feed-pipe in very compact form.

Among the obvious advantages to be derived from a use of my invention are a perfect and even circulation of the hot water through the system of pipes, an even distribution of hot water to the various radiators, and consequently an even distribution of heat throughout the building to be heated.

Other advantages are a saving of the number of joints from which connections are to be made. Thus, for instance, I employ but

three joints, thus saving the expense of making four extra joints and the inconvenience connected with their union. Furthermore, I diminish the chances of leakage in the same proportion that I economize in the number of joints. Again, I reduce the weight of the entire system of piping, saving the expense of the material and the increased strength necessary to support such piping. I also obtain great compactness in the construction of the system of piping, and I am enabled to extend the same in straight lines and thus avoid cutting through the joist or other wood or metal work of the building or of so connecting as to make special provisions for piping necessary.

My invention secures all of the advantages pertaining to the systems heretofore in use, together with many additional advantages, as specified.

It is obvious that I may make such modifications in my invention as do not depart from the spirit thereof, and especially that the system and pipe-fitting may be used with steam or air instead of hot water.

Having thus described my invention, what I claim as new, and desire to secure by Letters Patent of the United States, is—

1. In a heating system, a hollow pipe-fitting vertically disposed, the main feed-pipe communicating with said fitting at its top and bottom, the branch feed-pipe communicating with said fitting at one side, said fitting having a flange extending from its interior across the main feed-pipe from a point above the branch feed-pipe, said flange being curved downwardly and extending below the branch feed-pipe and across the line of feed in the main pipe, the said flange forming in connection with the interior walls of the fitting the passages E and F, substantially as and for the purposes specified.

2. In a heating system, the combination of the hollow fitting vertically disposed, the main feed-pipe communicating with it at its top and bottom and arranged at one side of its axial line, and the branch feed-pipe communicating with it at one side, said fitting forming a flange extending from its interior across the main feed-pipe from a point above the branch feed-pipe and curved downwardly forming with the interior walls of the fitting the passages E and F, and said fitting being also provided with a flange G<sup>3</sup> arranged to deflect the fluid toward the passage F, substantially as described.

OLIVER SCHLEMMER.

Attest:

J. C. LEMON,  
WM. E. JONES.